

Grafica's nano-print^{plus}

YOUR PLUS POINT



- Max print area: 22" x 28" (559 mm x 711 mm)
- No Compressor required
- Single Phase

plus features:

1. Adjustable screen frame holder
2. Variable printing stroke length
3. Single/Double stroke selection
4. Digital Stroke Counter
5. Parallel screen frame movement (Convenient for spot UV varnish and low viscosity inks to avoid ink spillage all over the screen)
6. Peel off mechanism (To achieve fine reproduction of halftone dots and avoid smudging, bleeding and smearing)

plus 'optional' features:

1. Vacuum by foot (to register on curly and unstable paper/ substrates accurately and easily)

Technical Features

1. PLC (Programable logic controller)
2. High quality electrical components
3. AC Motor of Class "F" Insulation
4. VFD (Variable Frequency Drive) for precise speed control
5. Imported geared motor (lifetime lubricated)
6. High quality steel fabrication
7. High quality pressure die-cast aluminum parts
8. Hard anodized aluminum extrusions
9. All moving parts hardened for longer life
10. Honey comb vacuum bed with stainless steel top
11. Zero backlash precision micrometer for vacuum bed movement to get accurate registration
12. Compact powerful vacuum blower to hold substrate firmly while printing
13. Squeegee head motion on precision imported guide rails
14. Imported timing belt for squeegee head movement
15. Independent squeegee and flood bar pressure control
16. Aluminum extruded squeegee holder
17. Aluminum extruded flood bar with 0.5 mm edge to print consistent halftones thus reduces ink deposition
18. Optional stainless steel edged flood bar to print ceramic / glass inks
19. Hard nickel plated metal parts to avoid corrosion
20. Hardened cams and shafts to increase life of machine thus reduces wear and tear
21. Castor wheels for easy mobility
22. Foot switch for easy operation
23. Auto mode to bypass foot switch
24. Safety bars to avoid accident
25. High safety standards

Technical Data

Description	Model: GF-2228 Nano-Print Plus
Max Print Area	22" x 28" (559 mm x 711 mm)
Vacuum Bed	26.7" x 35.9" (680 mm x 909 mm)
Vacuum Bed Movement for Registration	± 10 mm
Screen Frame Size	Min: 26" x 20" (606.4 mm x 508 mm) Max: 34" x 40" (863.6 mm x 1016 mm)
Max Off-Contact	10 mm
Max Substrate Thickness	5 ~ 7 mm (Depends on mesh tension)
Squeegee Holders	15.75" (400 mm) min & 24" (610 mm) max
Flood Coater	20" (508 mm) min & 26" (660 mm) max
Power Consumption	1.5 HP (1.2 kW)
Dimensions	As shown in the illustration below
Weight	310 Kg

nano-print^{plus} advantages

1. Single phase (plug n play)
2. No expensive air compressor required
3. Reduces manpower
4. Minimum maintenance
5. Minimum settings
6. Quick job changeover, faster production
7. No hidden cost, it's fully featured
8. Lower squeegee rubber cost (8 x 30 mm)
9. Requires less space 4.7' x 4.0' = approx. 19 sq. ft.
10. Screen frame holder compatible with aluminum, metal & wooden frames
11. Print with any types of solvent, plastisol and UV inks
12. Minimum investment, faster returns



Machine Dimension (in mm)

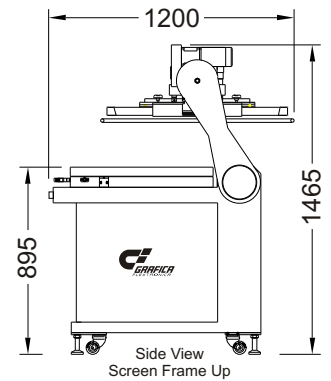
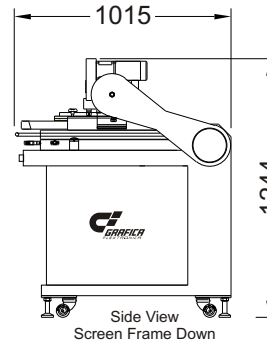
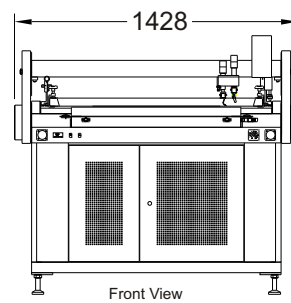

Precision Guide Rail

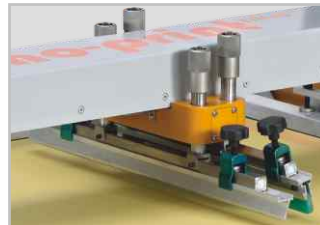

Quick change over of aluminum extruded squeegee and flood bar



High Quality AC Geared Motor



PLC (Programmable logic controller) and High Quality Electrical Components

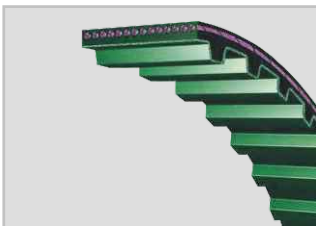

Imported timing belt for squeegee head movement



Compact Powerful Vacuum Blower



VFD (Variable Frequency Drive) for precise speed control

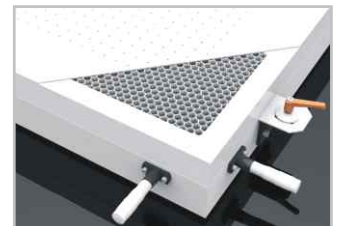

Sturdy, light weight honey comb vacuum bed with stainless steel top and precision micrometer to get accurate registration



GRAFICA FLEXTRONICA

Waliv Fata, Vasai East, Thane Dist, Maharashtra, India
 Tel: +91 250 2480998 / 9 Fax: +91 250 2480786
 Email: info@graficaindia.com
 Mobile: 9920466687 / 9920466617
www.grficaindia.com



A Division of Grafica Flextronica

LEARN MORE | EARN MORE:
 Educational Workshops & Seminars at DMI
 Log on to www.grficaindia.com to register
 for the next workshop.